

Aircraft Band Radio Receiver 118 - 137 mHz

Ramsey Model No. AR2

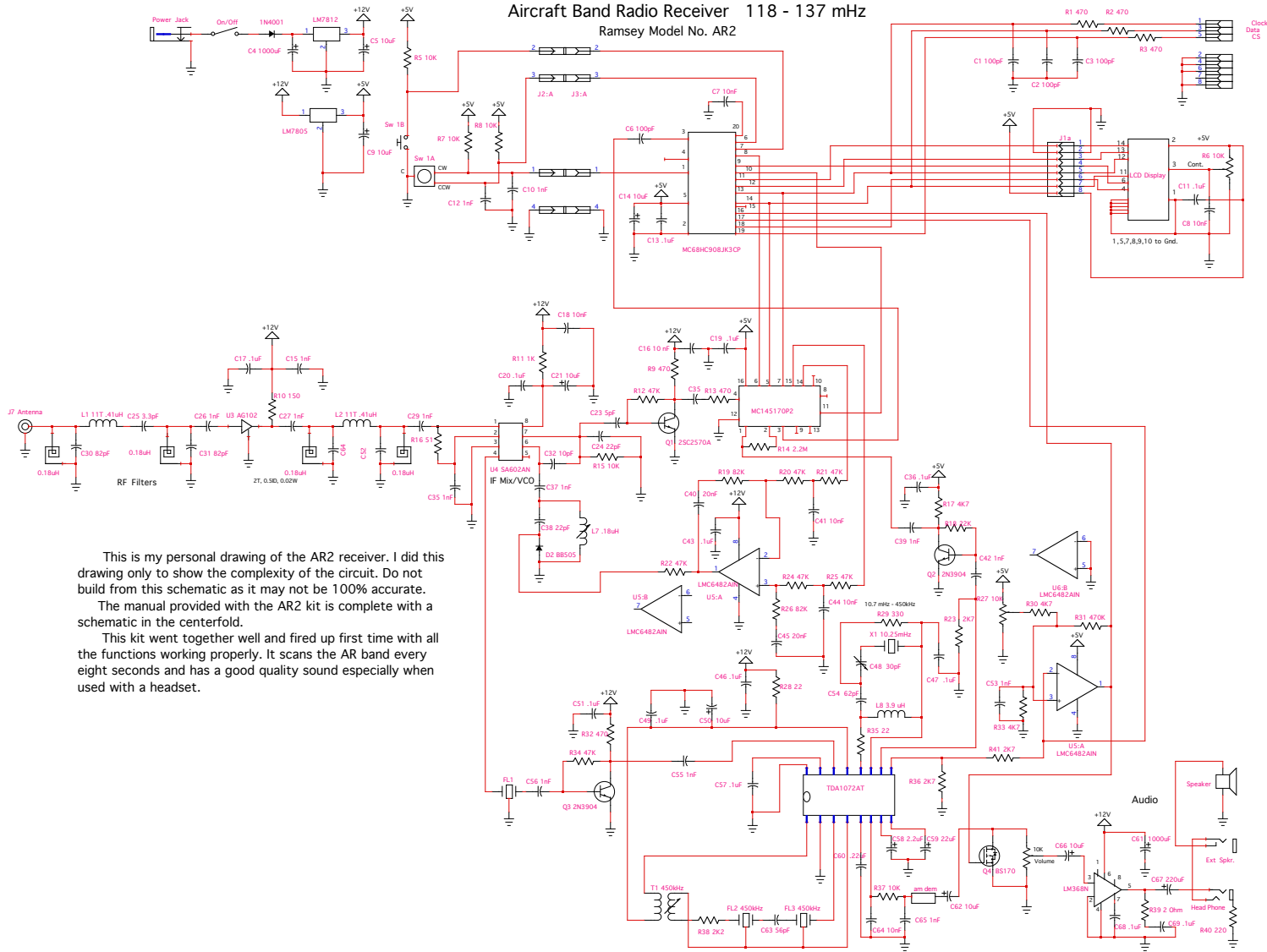

This is my personal drawing of the AR2 receiver. I did this drawing only to show the complexity of the circuit. Do not build from this schematic as it may not be 100% accurate.

The manual provided with the AR2 kit is complete with a schematic in the centerfold.

This kit went together well and fired up first time with all the functions working properly. It scans the AR band every eight seconds and has a good quality sound especially when used with a headset.